

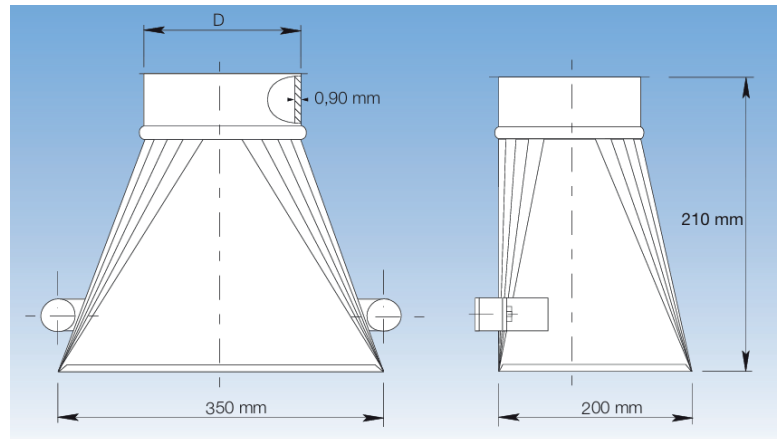

Freseskjerm, galvanisert, spennbåndskant.

Diameter \varnothing 100-150 mm.

Kan leveres med motasjemagnet.



Varenr	D (mm)	Vekt (kg)
4671601	100	1.5
4671602	120	1.75
4671603	125	1.89
4671604	140	2
4671605	150	2.25