

– ekspert på avslag

STFL

Flanges, stainless steel

Technical catalogue: Duct systems, stainless steel
Section: 04
Page: 1/2
Revised: 01.10.2008

Diameter: $\varnothing 80$ - $\varnothing 400$ mm.

Flanges are made in accordance with JKF's standard, and are a standard component in the product range.

Flanges are made in EN 1.4301 (AISI 304) stainless steel.

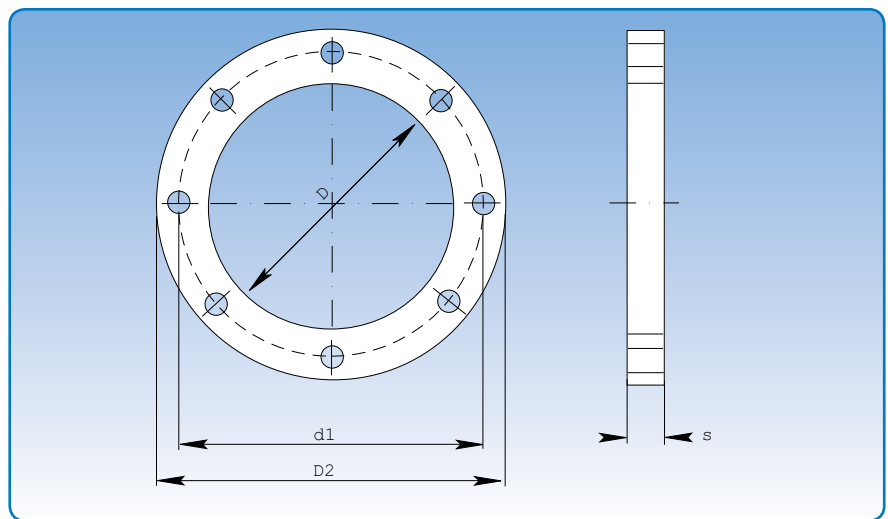

Dimensional specifications are given in the table below.

| Item no. | Diameter nominal | D mm | Dimensions | | | Flange width mm | Hole size mm | Number of holes | Weight kg |
|----------|------------------|------|------------|-------|------|-----------------|--------------|-----------------|-----------|
| | | | d1 mm | D2 mm | s mm | | | | |
| 1699508 | 80 | 83 | 115 | 133 | 3,00 | 25 | 9 | 8 | 0,19 |
| 1699510 | 100 | 103 | 135 | 153 | 3,00 | 25 | 9 | 8 | 0,22 |
| 1699512 | 120 | 123 | 155 | 173 | 3,00 | 25 | 9 | 8 | 0,26 |
| 1699514 | 140 | 143 | 175 | 193 | 3,00 | 25 | 9 | 8 | 0,30 |
| 1699515 | 150 | 155 | 185 | 205 | 3,00 | 25 | 9 | 8 | 0,42 |
| 1699518 | 175 | 180 | 210 | 230 | 4,00 | 25 | 9 | 8 | 0,50 |
| 1699520 | 200 | 205 | 235 | 255 | 4,00 | 25 | 9 | 12 | 0,54 |
| 1699522 | 224 | 230 | 260 | 280 | 4,00 | 26 | 9 | 12 | 0,60 |
| 1699525 | 250 | 255 | 285 | 305 | 4,00 | 25 | 9 | 12 | 0,66 |
| 1699530 | 300 | 305 | 336 | 355 | 4,00 | 25 | 9 | 12 | 0,78 |
| 1699535 | 350 | 355 | 389 | 415 | 5,00 | 26 | 11 | 12 | 1,37 |
| 1699540 | 400 | 405 | 439 | 465 | 5,00 | 30 | 11 | 16 | 1,54 |