

– ekspert på avsug

SCAND

Industrimiljø AS

www.scandmiljo.no

ROLLOUT – MOBILE CARTRIDGE FILTER

Rollout Mobile Cartridge Filter is designed to exhaust and filter dry air borne pollutants especially at welding, grinding, polishing, cutting of metals and plastics. Rollout features 3 stage filtration with metal mesh prefilter (spark-trap), main cartridge filter and outlet activated carbon filter. Standard manual (timer in option) regeneration system can be used to clean main cartridge during filter operation. Rollout is advised for most demanding applications where the constant exhaust and filter operation is required. We recommend Oskar 160 2 or 3 m models as a at source capture devices with Rollout filters. Optional configurations feature LED lights built-in Oskar arm hood as well as photosensor triggered automatic operation.

APPLICATION

- dry dusts or fumes capture and filtration especially at welding, grinding, cutting and many more processes (excluding corrosive, chemically aggressive and flammable gaseous mixtures)
- designed for continuous operation at heaviest and most demanding applications

CONSTRUCTION

- aluminium impeller 1,1 kW fan unit
- three stage filtration
- main cartridge total filter area 13 m²
- standard manual compressed air cartridge cleaning system
- 10 litre compressed air tank
- easy access dust drawers
- simple cartridge maintenance and exchange
- 2 swivel casters with brakes for more mobility
- heavy duty welded and powder coated construction



EXTREME FILTRATION
TECHNOLOGY INSIDE

– ekspert på avzug

SCAND

Industrimiljø AS

www.scandmiljo.no

TECHNICAL DATA

Airflow	1000 m ³ /h
Fan	1,1 kW
Fan rotation speed	2800 RPM
Standard power supply	3x 400 V +N+PE / 50 Hz, AC
Current Rating	2,7 A
Weight without arm	125 kg
Noise level	75 dB(A)
Filtration efficiency	99% @ 0,5 µm
Pre-filter	G1
Main filter	cartridge filter (13 m ²)
Outlet filter	G4 activated carbon material

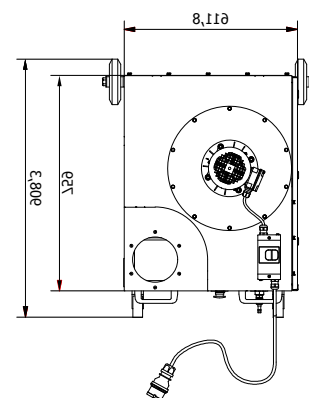
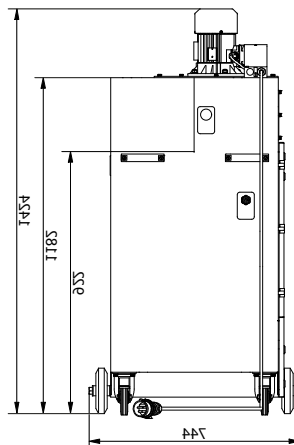
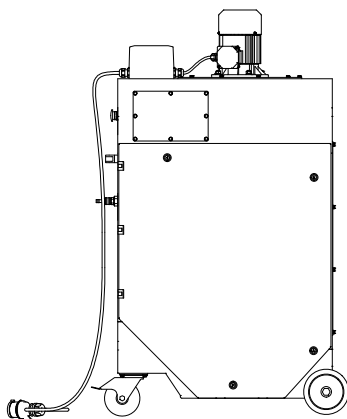
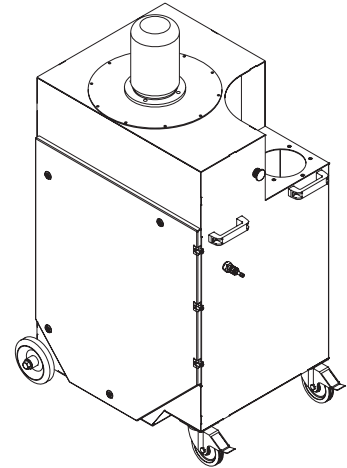

All diameters are given in mm

ROLLOUT – MOBILE CARTRIDGE FILTER

303 101 237 Mobile cartridge filter unit Rollout, nominal airflow 1000 m³/h. Including metal mesh spark trap, main polyester cartridge, activated carbon impregnated outlet filter, motor 1,1 kW, 400 V, 3 phase, 10 l compressed air tank, manual compressed air cleaning for main cartridge regeneration.

ROLLOUT – ARMS AND OPTIONS

W02-01-1620P	Oskar fume arm 1620P, reach 2 m, hood inlet Ø315 mm
W02-01-1630P	Oskar fume arm 1630P, reach 3 m, hood inlet Ø315 mm
W02-HA-1620P	Hose arm 2 m, hood inlet Ø315 mm
W02-HA-1630P	Hose arm 3 m, hood inlet Ø315 mm
P02-80-0101	MOD-L - light kit option with transformer for one Oskar arm
P02-80-0102	MOD-A + ZAR-A - light kit and automatic (welding arc triggered) fan start/stop option for one Oskar arm
P02-80-0301	TC-1 - timer controlled compressed air cleaning operation

ROLLOUT – SPARE PARTS

242 079	Polyester cartridge
240 672	Outlet filter (activated carbon impregnated material)
240 007	Metal mesh spark trap
M03-23-0004	Swivel caster with brake 125
M03-23-0007	Wheel 160