

PE



Industrial strength in capturing:

- **WELDING FUMES**
- **GRINDING DUSTS**
- **DRY DUSTS**
- **SOLDERING FUMES**
- **POWDERS**

and much more...

Applications:

Welding • Grinding • Polishing • Cutting
Soldering • Chemical Fumes and much more!

Features:

- industrial strength
- versatile design
- smooth tube construction
- external joints and supports
- hood and tube grab handles
- air diverter in the hood
- standard damper

The fume arms are the most versatile, durable and economical method for capturing air impurities at their source. The construction of steel tubes, flexible hose at joints and external cast aluminium joints allow the arm to be positioned where needed. The fume arms come in diameters of 75, 100, 125, 160 and 200mm and lengths up to 4m.

Benefits:

- long lasting
- user-friendly operation
- higher airflow performance
- easy to adjust and maintain
- simple positioning
- increased capture velocity
- damper with-in the price

All of the fume arms can be easily equipped with a light kit or larger hood diameters. Oskar's Fume Arms combine easily with the Sliding Suction Rails, Extension Booms, Fans and Modular Units.



All External Joints and Supports



Standard Damper



Air Diverter and Grab Handle
all around the Hood

Industrial Strength Construction

- 1 HOOD JOINT**
Hood easily positions forward, backward and sideways.
All external adjustments.
Flexible hose with gear clamps

- 2 MIDDLE JOINT**
All external adjustments.
Flexible hose with gear clamps.

- 3 SOCKET JOINT**
Rotating swivel with safety stop.
All external adjustments.
Flexible hose with gear clamps.

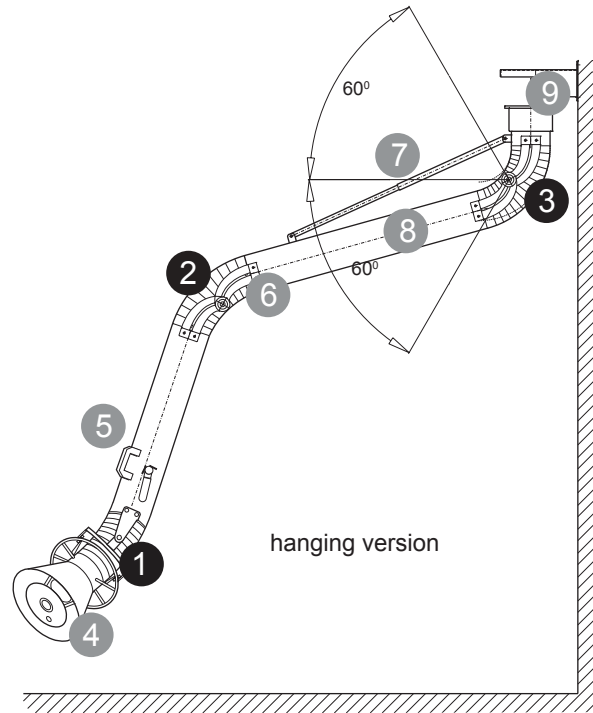
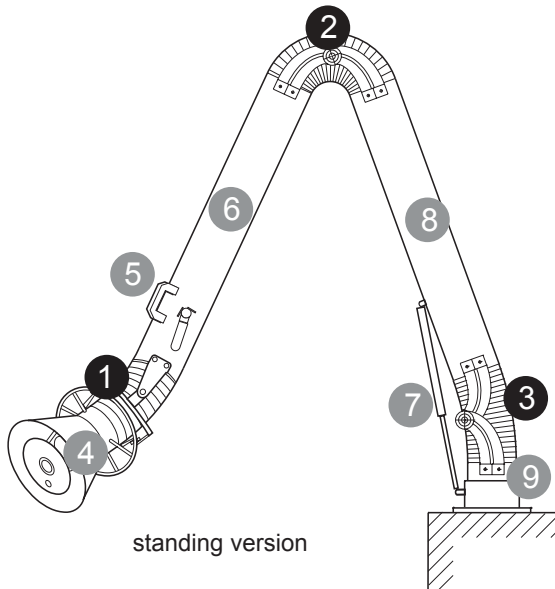

- 4** Aluminium hood (powder coated) with surrounding grab handle, ready to be fitted with optional light kit.
- 5** Additional tube grab handle.
- 6** Smooth steel tube (powder coated) with standard damper.
- 7** Support spring or gas shock on the outside on both versions.

- 8** Smooth steel tube (powder coated).
- 9** Swivel base with predrilled mounting holes

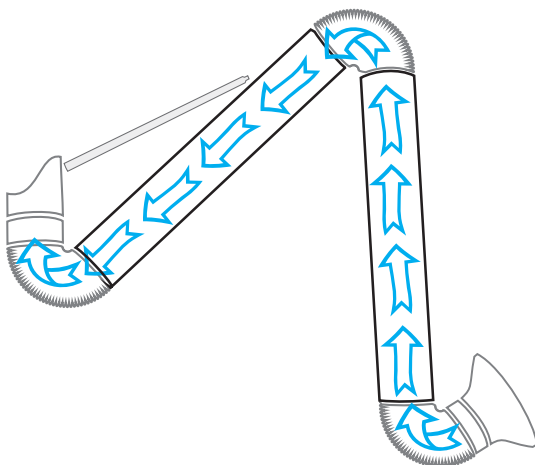

External components

- smooth airflow
- low static pressure
- quick cleaning
- minimal build up

Technical Data

Model	Arm reach [feet]/[m]	Arm diameter [inch]/[mm]	Hood diameters [inch]/[mm]
0710	3 / 1,0	3 / 76	4 / 160
0715	5 / 1,5	3 / 76	4 / 160
1015	5 / 1,5	4 / 100	8 / 200
1020	7 / 2,0	4 / 100	8 / 200
1025	8 / 2,5	4 / 100	8 / 200
1220	7 / 2,0	5 / 125	12 / 315
1225	8 / 2,5	5 / 125	10 / 315
1230	10 / 3,0	5 / 125	12 / 315
1620	7 / 2,0	6 / 160	12 (14) / 315 (350)
1630	10 / 3,0	6 / 160	12 (14) / 315 (350)
1640	14 / 4,0	6 / 160	12 (14) / 315 (350)
2020	7 / 2,0	8 / 200	14 (20) / 350 (500)
2030	10 / 3,0	8 / 200	14 (20) / 350 (500)
2040	14 / 4,0	8 / 200	14 (20) / 350 (500)

Static Pressure & Air Flow

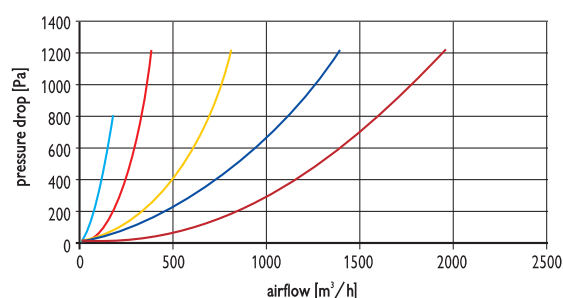
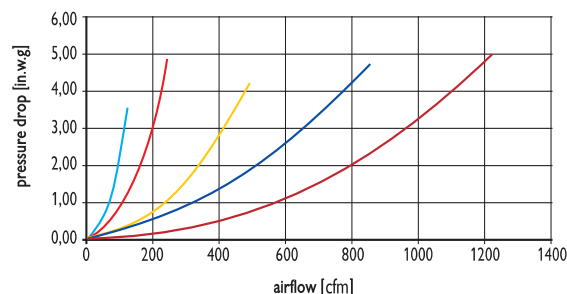

Standard wall mounting brackets

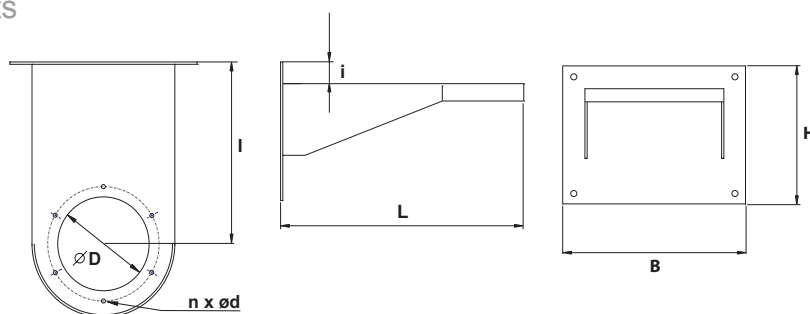
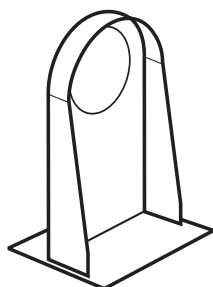

Bracket type Ø [in.]/[mm]	n	Ø D [in.]/[mm]	l [in.]/[mm]	L [in.]/[mm]	i [in.]/[mm]	B [in.]/[mm]	H [in.]/[mm]	weight lb/[kg]	Part number
3"/ 76	4	3.15 / 80	3.54 / 90	6.69 / 170	-	5.43 / 138	3.94 / 100	1 / 0.45	P07010001
4"/ 100	4	3.94 / 100	3.94 / 100	7.48 / 190	-	6.30 / 160	3.94 / 100	1 / 0.45	P07010002
5"/ 125	6	4.92 / 125	6.02 / 153	9.96 / 253	1.38 / 35	9.45 / 240	6.30 / 160	8 / 3.6	P07010003
6"/ 160	6	6.30 / 160	10.00 / 254	14.72 / 374	1.38 / 35	9.84 / 250	6.50 / 165	8 / 3.6	P07010004
8"/ 200	8	8.07 / 205	12.36 / 314	18.11 / 460	1.57 / 40	12.99 / 330	9.84 / 250	14 / 6.3	P07010005